

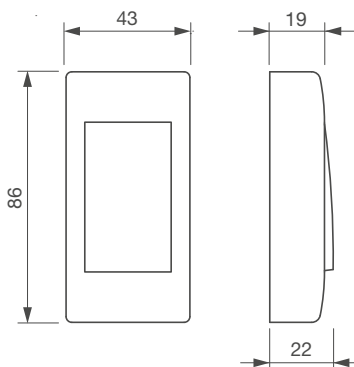

➤ EXS43AP

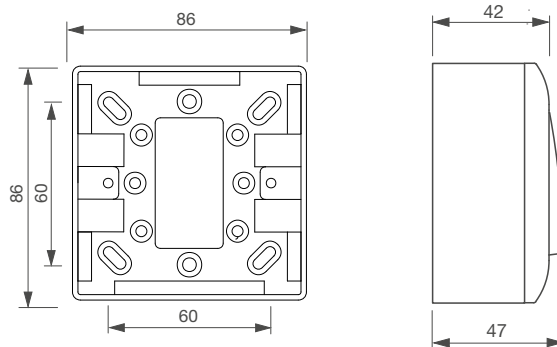

➤ EXS86AP



➤ EXS86ENC

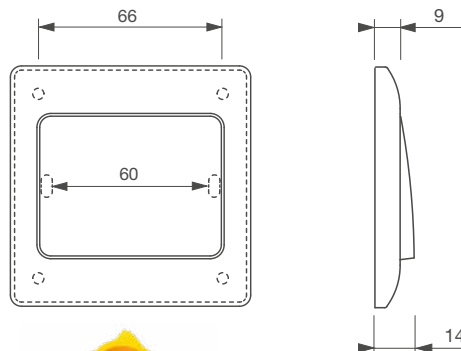

➤ Compatibles boîtes d'encastres électriques normalisées

Références	EXS43AP ⁽¹⁾			EXS86AP ⁽¹⁾		EXS86ENC ⁽¹⁾		OPTION	
	Applique			Encastré		Encastré		PSH86	
Montage	Applique			Encastré		Encastré		Boitier Applique pour bouton poussoir EXS en ABS blanc	
Matière	ABS								
Mode de fonctionnement	Impulsionnel								
Contact	Inverseur CO/NO/NF								
Pouvoir de coupure max.	36V / 3A								
Raccordement	Borniers à vis								
Température de fonctionnement / Humidité relative	-5° à +55° C / 85 % HR								
Indice de protection IP	IP 42			IP 40		IP 42		86 x 86 x 30 mm	
Dimensions (l x h x p)	86 x 43 x 22/19 mm			86 x 86 x 38/44 mm		86 x 86 x 8/14 mm		86 x 86 x 30 mm	
Poids brut / Poids net	0,056 Kg / 0,032 Kg			0,150 Kg / 0,124 Kg		0,073 Kg / 0,045 Kg		0,105 Kg / 0,074 Kg	
Conditionnement par	1								
Code douane	8536501199								
Code EAN 13	3760351750168			3760351730151		3760351730144		3760351730137	



CAFR10A-220316-H

⁽¹⁾ Disponible début 2022