

## IP RAINBOW SERIES

Provision-ISR's Rainbow cameras, equipped with CNV (Color Night Vision) technology, yield sharp and superior colors even in poor light conditions, providing visual details that significantly contribute to identifying people or objects.



# DV-320SRN-28

## 2MP 24/7 FULL-COLOR FIXED LENS DOME/TURRET CAMERA

The rainbow camera series is equipped with super light-sensitive sensors that allow the camera to provide a color image throughout the day. When the ambient light is insufficient, the camera will turn on the integral lighting, allowing it to continue providing a full-color image. With its outstanding performance, reliability, and affordable price, the DV-320SRN-28 camera is the perfect solution for indoor/outdoor installations.



### MAIN FEATURES

- 2MP
- RAINBOW
- S-SIGHT V2
- 1920x1080 Resolution
- 3D-DNR
- IP67

### ANALYTICS

- General Analytics: Camera Tampering
- Standard Analytics: Line Crossing, Sterile Area



## SPECIFICATIONS

Image Sensor	1/2.8" CMOS (16:9)
Effective Pixels	1920x1080
Electronic Shutter	1/25s ~ 1/100000s
Frame Rate	1-25/30 FPS
Min. Illumination	0 lux with LED
D&N	24/7 Full-Color Day Mode
Audio Compression	G.711A/G.711U
Communication	One-way Audio
Image Settings	AWB, AGC Adjustable, Exposure Mode (Auto) Sharpness, Saturation, Brightness & Contrast Adjustable
Image Enhancement	True WDR (120dB), BLC, HLC, ROI
Noise Reduction	3D-DNR
Image Orientation	Mirror/Flip
Privacy Zone	Yes
Motion Detection	Yes
Analytics	General Analytics: Camera Tampering Standard Analytics: Line Crossing, Sterile Area
Video Compression	H.265 / H.264 / H.265+ / H.264+ / MJPEG**
Resolution	2MP / 1MP / D1 (704x576) / QVGA (480x240) / CIF (352x288)
Multi-Stream	Master Stream: 2MP (1920x1080) / 1MP (1280x720) (1~30fps) Substream: QVGA/D1/CIF Third Stream: QVGA/D1/CIF (1~30fps)
Bit rate	64Kbps ~ 4Mbps@H.265 / 64Kbps ~ 6Mbps@H.264
Encode Mode	VBR/CBR
Image Quality	Five levels under VBR; Free adjustment under CBR
IR Distance	25m (2 High-Power White LED)
Lens (Field of View)	2.8mm (105.2°)

## SPECIFICATIONS

Iris	Fixed Iris (F1.0)
Lens Mount	M12 mount
Protection Rate	Water Proof: IP67
Bracket	3-Axis Bracket
Dimensions	Ø97mm×82.6mm
Weight (gross)	~450g
Network	RJ45 (+PoE)
Power	DC Socket
Analog Video Output	No
Audio Connectivity	Built-in Microphone
SD Card	Event/Schedule based Main/Substream recording (Up to 128Gb)
Hard Reset Button	Yes
Alarm	No
Remote Monitoring	Web Browsing, Ossia VMS Software, Provision Cam2 Mobile App
User Access	Supports simultaneous monitoring of up to 3 users with multi-stream real-time transmission
Network Protocol	IPv4, IPv6, TCP, UDP, DHCP, NTP, DDNS, 802.1X, RTSP, Multicast, UPnP, Email, FTP, HTTPS, QoS
ONVIF	Yes
Ethernet	100Mbps
PoE	Yes
Power Supply	DC12V/~420mA / PoE/~5.4W
Work Environment	-30°C~60°C, 10%~90% Humidity
Junction Box	PR-JB12IP66 - PR-JB12IP64

## DIMENSIONS

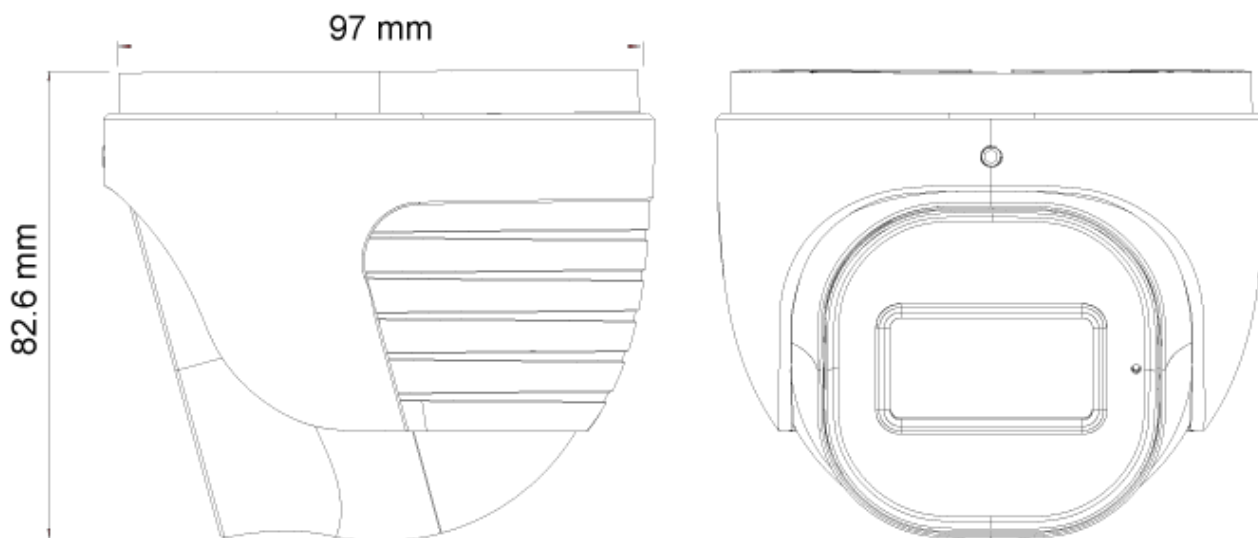

## ACCESSORIES



PR-JB12IP66

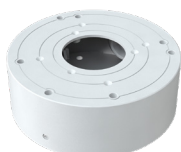

PR-JB12IP64