

# NOTICE DE MISE EN OEUVRE

ST\_K\_RANGE\_E\_170905



**K1000 - KR1000 - KRN1000**

## CARACTÉRISTIQUES TECHNIQUES

|                                      |                        |  |                 |        |                         |                               |                                  |  |     |
|--------------------------------------|------------------------|--|-----------------|--------|-------------------------|-------------------------------|----------------------------------|--|-----|
| h x l x p                            |                        |  |                 |        |                         |                               |                                  |  |     |
| 120 x 76 x 28 mm<br>165 x 45 x 22 mm |                        | 0,7 kg<br>0,6 kg   | 12/24V<br>AC/DC | 110 mA | sortie<br>relais<br>= 2 | 30V DC - 2 A<br>125VAC - 0,5A | entrée<br>bouton poussoir<br>= 2 | 1010<br>Relais 1 = 1000<br>Relais 2 = 10 | 65* |
| <b>K1000</b>                         |                        | <b>1 mode de fonctionnement :</b><br>• <b>CLAVIER A CODE</b><br>→ <b>ATTENTION :</b><br><i>Chaque code doit être unique</i>  |                 |        |                         |                               |                                  | 0 - 99 s                                 |     |
| <b>KR1000</b><br><b>KRN1000</b>      | <br>125 KHz<br>(MARIN) | <b>3 modes de fonctionnement :</b><br>• <b>LECTEUR DE PROXIMITÉ</b><br>• <b>LECTEUR DE PROXIMITÉ ou CODE</b><br>• <b>LECTEUR DE PROXIMITÉ + CODE</b><br>→ <b>ATTENTION :</b><br><i>dans ce cas, tous les utilisateurs doivent avoir 1 CODE et 1 BADGE DE PROXIMITÉ</i> |                 |        |                         |                               |                                  | -10+60°C                                 |     |

\*IP 65 : Protection contre les poussières, pas de dépôts nuisibles. Protection contre les jets d'eau à la lance de toutes directions

## DIMENSIONS

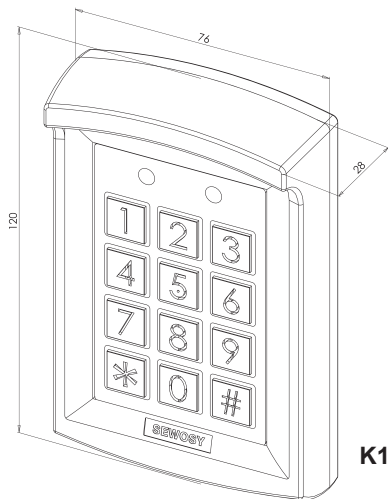

**K1000 - KR1000**

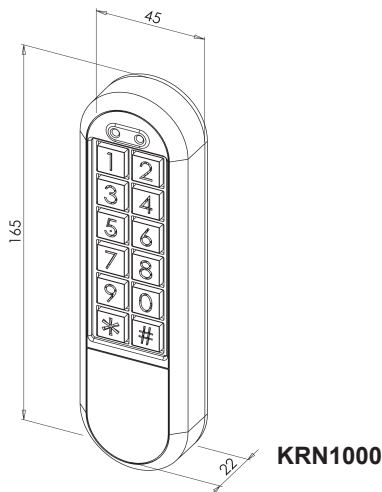

**KRN1000**

**ATTENTION : Veuillez respecter la polarité et la tension d'alimentation 12/24V AC/DC !**

Lire attentivement cette notice avant mise en service et utilisation.

Utiliser ce matériel pour une application adaptée. Le fabricant n'est pas responsable des dommages éventuels causés par une utilisation contraire aux dispositions de sécurité.

Le montage, la maintenance et les réparations doivent être réalisés par un personnel spécialisé et autorisé.

La mise en oeuvre est très simple, mais une manipulation correcte et un entretien approprié sont des conditions essentielles pour garantir un fonctionnement parfait.



13b rue Saint-Exupéry - ZA de l'Aérodrome - CS20152 - FR-67503 HAGUENAU CEDEX www.sewosy.com

Tél. +33 (0)3 90 59 02 20 Fax + 33 (0)3 90 59 02 19

Sous réserve de modifications techniques !



## MONTAGE

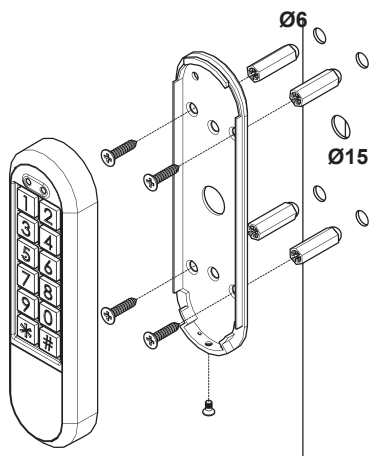
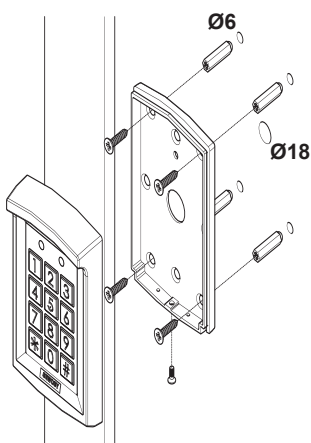

## RACCORDEMENT

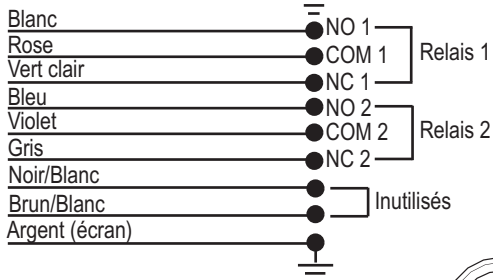
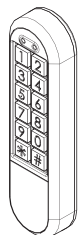
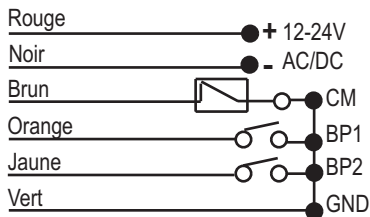
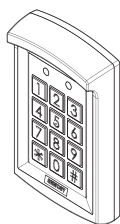

**BP 1**  
 = Bouton poussoir Relais 1  
**BP 2**  
 = Bouton poussoir Relais 2  
**CM**  
 = Contact Magnétique\*  
  
 = Sonnette\*  
 \* Voir **fonction sonnette** en page 8/24

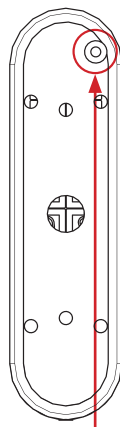
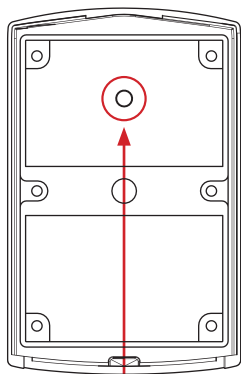

 Cellule photoélectrique d'autoprotection. Pour l'activer se référer à la page 8/24 "Autoprotection"

\*CM (Contact magnétique) : Si branchement d'un contact magnétique de porte sur cette entrée, en cas de temporisation assignée au contrôle d'accès, celle-ci s'annule lorsque que la porte est à nouveau fermée.

# EXEMPLES DE CONFIGURATIONS

## RACCORDEMENT D'UNE GÂCHE ELECTRIQUE\* VERROUILLAGE À ÉMISSION

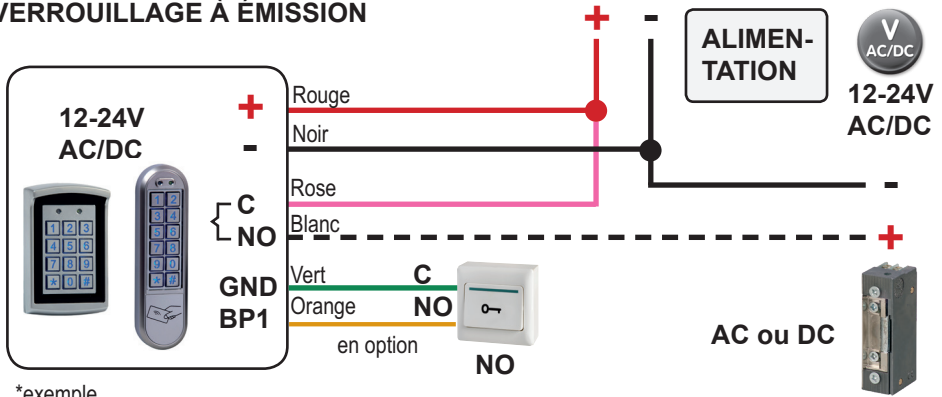

## RACCORDEMENT D'UN PORTAIL\* VERROUILLAGE À ÉMISSION

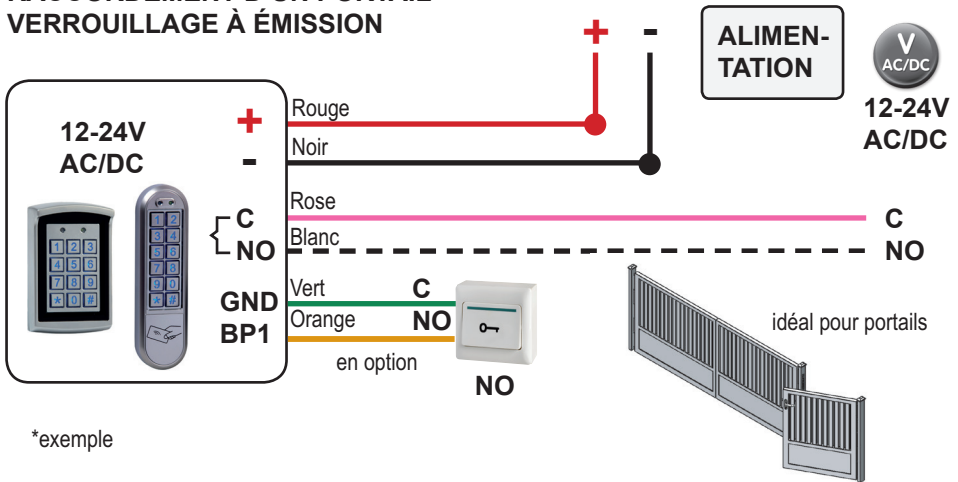

## RACCORDEMENT D'UNE VENTOUSE ÉLECTROMAGNÉTIQUE\* VERROUILLAGE À RUPTURE

\*exemple

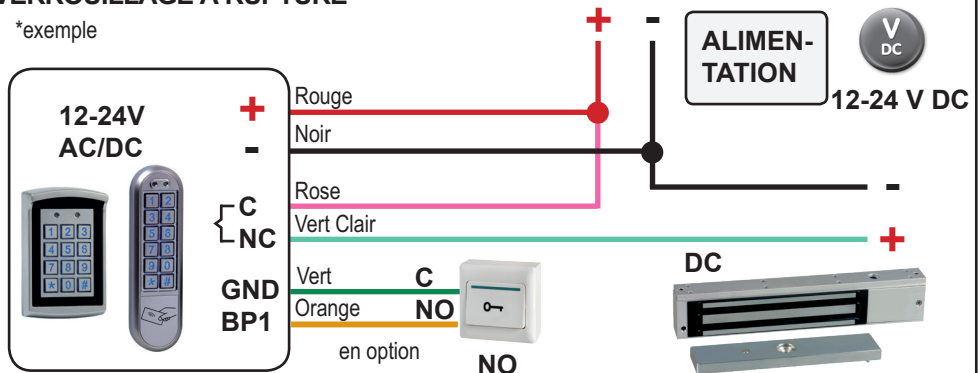

## PROGRAMMATION

### Modification du nombre de chiffres (codes)

Attention : à modifier avant la première programmation d'un code (réglage usine = 4 chiffres)

|  |   |
|--|---|
| Entrer <b>2 X</b> le code maître (code maître d'origine : 1234)  | BIP long + LED droite orange fixe                 |
| Entrer * <b>904</b>  | BIP long + LED droite orange clignotante          |
| Entrer la valeur ( <b>X</b> compris entre 2 et 6)  | BIP long + LED droite orange fixe                 |
| <b>Une modification du nombre de chiffres efface tous les enregistrements</b>  |   |
|  Si <b>X</b> = 2, le code maître est <b>12</b> | Si <b>X</b> = 5, le code maître est <b>12345</b>  |
| Si <b>X</b> = 3, le code maître est <b>123</b>   | Si <b>X</b> = 6, le code maître est <b>123456</b> |
| Si <b>X</b> = 4, le code maître est <b>1234</b>  |   |
| Entrer <b># #</b>  | LED droite verte fixe                             |

### Créer une carte maître

La carte maître vous permet de rentrer en programmation

|   |  |
|---|--|
| Entrer <b>2 X</b> le code maître (code maître d'origine : 1234) | BIP long + LED droite orange fixe                            |
| Entrer * <b>7</b>   | LED droite orange clignotante + LED gauche verte clignotante |
| Passer la carte <b>1 X</b>                                      | BIP long + LED droite orange fixe                            |
| Entrer <b># #</b>   | LED droite verte fixe  |

### Modifier une carte maître

|  |  |
|--|--|
| Entrer <b>2 X</b> le code maître ou passer la carte maître <b>1 X</b> (code maître d'origine : 1234) | BIP long + LED droite orange fixe                                |
| Entrer * <b>7</b>  | LED droite orange clignotante + LED gauche verte fixe            |
| Entrer <b>**</b>   | BIP long + LED droite orange clignotante + LED gauche verte fixe |
| Passer la carte <b>1 X</b>   | BIP long + LED droite orange fixe                                |
| Entrer <b># #</b>  | LED droite verte fixe  |

### Changer le code maître

Pour des raisons de sécurité il est recommandé de modifier le code maître permettant de rentrer en programmation. Aucun code utilisateur ne peut être identique

|  |                                   |
|--|-----------------------------------|
| Entrer <b>2 X</b> le code maître ou passer la carte maître <b>1 X</b> (code maître d'origine : 1234) | BIP long + LED droite orange fixe |
| Entrer * <b>3</b>  | LED droite orange clignotante     |
| Entrer le nouveau code <b>2 X</b>  | BIP long + LED droite orange fixe |
| Entrer <b># #</b>  | LED droite verte fixe             |

### Restaurer le code maître d'origine (1234)

(en cas de code maître perdu ou oublié)

|  |   |
|--|---|
| Couper l'alimentation du clavier.<br>Appuyer sur <b>#</b> . Maintenir cette touche appuyée 3 sec.<br>pendant que l'on rebranche l'alimentation | Les LED s'éteignent<br><br>BIP long + LED droite verte fixe |
|--|---|

## Ajouter un utilisateur

**ATTENTION : Le code maître ne permet pas de déverrouiller la porte!**

► **RELAIS 1 (de 001 à 999 utilisateurs)** ◀

### CARTE OU CODE

|   |  |
|---|--|
| Entrer <b>2 X</b> le code maître ou passer la carte maître <b>1 X</b><br>(code maître d'origine : 1234) | BIP long + LED droite orange fixe                        |
| Entrer * <b>001</b>   | BIP long + LED droite orange fixe                        |
| Entrer la position de <b>001 à 999</b><br>( <b>3 digits obligatoires</b> )                              | LED gauche verte fixe<br>+ LED droite orange clignotante |
| <b>si CARTE</b> : Passer la carte <b>1 X</b><br><b>si CODE</b> : Entrer un code <b>1 X</b>              | BIP long + LED droite orange fixe                        |
| Entrer <b># #</b>   | LED droite verte fixe                                    |

### CARTE ET CODE

(dans ce cas le relais 2 est inactif)

|   |  |
|---|--|
| Entrer <b>2 X</b> le code maître ou passer la carte maître <b>1 X</b><br>(code maître d'origine : 1234) | BIP long + LED droite orange fixe                        |
| Entrer * <b>002</b>   | BIP long + LED droite orange fixe                        |
| Entrer la position de <b>001 à 999</b><br>( <b>3 digits obligatoires</b> )                              | LED gauche verte fixe<br>+ LED droite orange clignotante |
| Passer la carte <b>1 X</b> et entrer un code <b>1 X</b>   | BIP long + LED droite orange fixe                        |
| Entrer <b># #</b>   | LED droite verte fixe                                    |

► **RELAIS 2 (de 00 à 09 utilisateurs)** ◀

### CARTE OU CODE

|   |  |
|---|--|
| Entrer <b>2 X</b> le code maître ou passer la carte maître <b>1 X</b><br>(code maître d'origine : 1234) | BIP long + LED droite orange fixe                        |
| Entrer * <b>4</b>   | LED droite orange clignotante                            |
| Entrer la position de <b>00 à 09</b><br>( <b>2 digits obligatoires</b> )                                | LED gauche verte fixe<br>+ LED droite orange clignotante |
| <b>si CARTE</b> : Passer la carte <b>1 X</b><br><b>si CODE</b> : Entrer un code <b>1 X</b>              | BIP long + LED droite orange clignotante                 |
| Entrer <b># #</b>   | LED droite verte fixe                                    |



**Les codes ou cartes utilisateurs du relais 1 et 2 doivent être différents les uns des autres.**

## Supprimer un utilisateur

### ► RELAIS 1 (de 001 à 999 utilisateurs) ◀

|   |   |
|---|---|
| Entrer <b>2 X</b> le code maître ou passer la carte maître <b>1 X</b><br>(code maître d'origine : 1234) | BIP long + LED droite orange fixe                                   |
| Entrer la position à 3 digits obligatoires<br>(de 001 à 999)  | LED gauche rouge fixe<br>+ LED droite orange clignotante            |
| Entrer **   | BIP long + LED gauche verte fixe<br>+ LED droite orange clignotante |
| Entrer ##   | LED droite verte fixe   |
| <b>► RELAIS 2 (de 00 à 09 utilisateurs) ◀</b>   |   |
| Entrer <b>2 X</b> le code maître ou passer la carte maître <b>1 X</b><br>(code maître d'origine : 1234) | BIP long + LED droite orange fixe                                   |
| Entrer * 4  | LED droite orange clignotante                                       |
| Entrer la position à 2 digits obligatoires<br>(de 00 à 09)  | LED gauche rouge fixe<br>+ LED droite orange clignotante            |
| Entrer **   | BIP long + LED gauche verte fixe<br>+ LED droite orange clignotante |
| Entrer ##   | LED droite verte fixe   |

## Supprimer tous les utilisateurs

**Tous les codes et les cartes utilisateurs sont supprimés**

|   |                                   |
|---|-----------------------------------|
| Entrer <b>2 X</b> le code maître ou passer la carte maître <b>1 X</b><br>(code maître d'origine : 1234) | BIP long + LED droite orange fixe |
| Entrer * 888  | BIP long + LED droite orange fixe |
| Entrer ##   | LED droite verte fixe             |

## Retour réglage d'usine

**Cette manipulation efface tous les codes et cartes utilisateurs + la carte maître et le code maître d'origine est restauré : 1234**

|   |                                   |
|---|-----------------------------------|
| Entrer <b>2 X</b> le code maître ou passer la carte maître <b>1 X</b><br>(code maître d'origine : 1234) | BIP long + LED droite orange fixe |
| Entrer * 899  | BIP long + LED droite verte fixe  |
| Entrer ##   | LED droite verte fixe             |

## Temporisation des relais

### ▶ RELAIS 1 (de 01 à 99 secondes) ◀

|   |                                   |
|---|-----------------------------------|
| Entrer <b>2 X</b> le code maître ou passer la carte maître <b>1 X</b><br>(code maître d'origine : 1234) | BIP long + LED droite orange fixe |
| Entrer * 1  | LED droite orange clignotante     |
| Entrer la valeur à 2 digits obligatoires (de 01 à 99 sec.)<br>ou entrer <b>00 (fonction bistable)</b>   | BIP long + LED droite orange fixe |
| Entrer # #  | LED droite verte fixe             |
| <b>▶ RELAIS 2 (de 01 à 99 secondes) ◀</b>   |                                   |
| Entrer <b>2 X</b> le code maître ou passer la carte maître <b>1 X</b><br>(code maître d'origine : 1234) | BIP long + LED droite orange fixe |
| Entrer * 5  | LED droite orange clignotante     |
| Entrer la valeur à 2 digits obligatoires (de 01 à 99 sec.)<br>ou entrer <b>00 (fonction bistable)</b>   | BIP long + LED droite orange fixe |
| Entrer # #  | LED droite verte fixe             |

## Buzzer

Si le buzzer est désactivé, la LED orange de gauche le remplace

### ▶ ACTIVER ◀

|   |                                   |
|---|-----------------------------------|
| Entrer <b>2 X</b> le code maître ou passer la carte maître <b>1 X</b><br>(code maître d'origine : 1234) | BIP long + LED droite orange fixe |
| Entrer * 203  | BIP long + LED droite orange fixe |
| Entrer # #  | LED droite verte fixe             |

### ▶ DESACTIVER ◀

|   |   |
|---|---|
| Entrer <b>2 X</b> le code maître ou passer la carte maître <b>1 X</b><br>(code maître d'origine : 1234) | BIP long + LED droite orange fixe                   |
| Entrer * 204  | Flash orange LED gauche<br>+ LED droite orange fixe |
| Entrer # #  | Flash orange LED gauche<br>+ LED droite verte fixe  |

## Autoprotection

Active le buzzer en cas d'arrachement

### ► ACTIVER ◀

|   |                                   |
|---|-----------------------------------|
| Entrer <b>2 X</b> le code maître ou passer la carte maître <b>1 X</b><br>(code maître d'origine : 1234) | BIP long + LED droite orange fixe |
| Entrer * 6  | LED droite orange clignotante     |
| Entrer 02   | BIP long + LED droite orange fixe |
| Entrer # #  | LED droite verte fixe             |

### ► DESACTIVER ◀

|   |                                   |
|---|-----------------------------------|
| Entrer <b>2 X</b> le code maître ou passer la carte maître <b>1 X</b><br>(code maître d'origine : 1234) | BIP long + LED droite orange fixe |
| Entrer * 6  | LED droite orange clignotante     |
| Entrer 01   | BIP long + LED droite orange fixe |
| Entrer # #  | LED droite verte fixe             |



## Fonction sonnette

Si la fonction sonnette est activée,  
les cartes et codes programmés ne sont plus fonctionnels sur le relais 2.  
Cette fonction permet le remplacement d'une sonnette.  
Pour sonner appuyer sur la touche \*

### ► ACTIVER ◀

|   |                                   |
|---|-----------------------------------|
| Entrer 2 X le code maître ou passer la carte maître 1 X<br>(code maître d'origine : 1234) | BIP long + LED droite orange fixe |
| Entrer * 2  | LED droite orange clignotante     |
| Entrer 02   | BIP long + LED droite orange fixe |
| Entrer # #  | LED droite verte fixe             |

### ► DESACTIVER ◀

|   |                                   |
|---|-----------------------------------|
| Entrer 2 X le code maître ou passer la carte maître 1 X<br>(code maître d'origine : 1234) | BIP long + LED droite orange fixe |
| Entrer * 2  | LED droite orange clignotante     |
| Entrer 01   | BIP long + LED droite orange fixe |
| Entrer # #  | LED droite verte fixe             |

**Remarque:** Après 5 tentatives erronées consécutives (codes), le clavier sera bloqué durant 60 secondes. Aucune manipulation ne pourra être effectuée durant ces 60 secondes.





### TECHNICAL DATA

|                                      |                        |  |                 |        |                         |                               |                             |  |     |
|--------------------------------------|------------------------|--|-----------------|--------|-------------------------|-------------------------------|-----------------------------|--|-----|
| H x W x D                            |                        |  |                 |        |                         |                               |                             |  |     |
| 120 x 76 x 28 mm<br>165 x 45 x 22 mm |                        | 0,7 kg<br>0,6 kg   | 12/24V<br>AC/DC | 110 mA | output<br>relays<br>= 2 | 30V DC - 2 A<br>125VAC - 0,5A | input<br>exit button<br>= 2 | 1010<br>Relay 1 = 1000<br>Relay 2 = 10 | 65* |
| <b>K1000</b>                         |                        | <b>1 operating mode :</b><br><ul style="list-style-type: none"> <li>• <b>KEYPAD</b></li> </ul> → <b>ATTENTION :</b><br><i>each code has to be absolutely unique</i>  |                 |        |                         |                               |                             | 0 - 99 s                               |     |
| <b>KR1000</b><br><b>KRN1000</b>      | <br>125 KHz<br>(MARIN) | <b>3 operating modes :</b><br><ul style="list-style-type: none"> <li>• <b>STAND-ALONE PROXIMITY READER</b></li> <li>• <b>STAND-ALONE PROXIMITY + PIN CODE</b></li> <li>• <b>STAND-ALONE PROXIMITY + PIN CODE</b></li> </ul> → <b>ATTENTION :</b><br><i>in this case, all users must have 1 PIN CODE and 1 PROXIMITY CARD</i> |                 |        |                         |                               |                             | -10+60°C                               |     |

\*IP 65 : Protection against intrusion of dust. Protection against low pressure water jets from any direction.

### DIMENSIONS

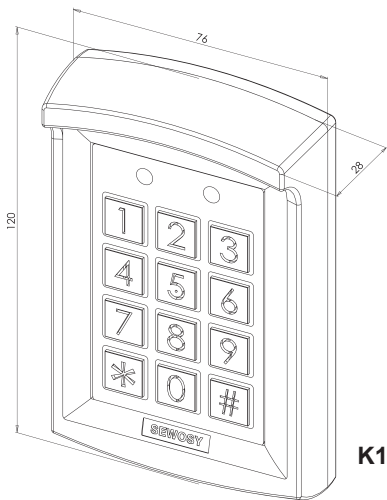

**K1000 - KR1000**

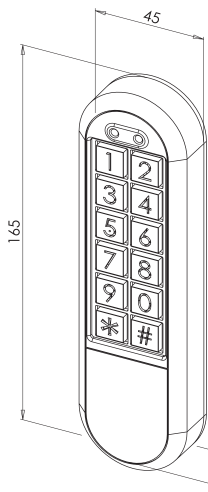

**KRN1000**

**ATTENTION : Make sure to observe correct polarity and input voltage: 12/24V AC/DC as specified!**

Read carefully this user guide before activating and using. Use this equipment only for an adapted application. The manufacturer cannot be held responsible for possible damage caused when usual security requirements are not fulfilled. Mounting, maintenance and repair must be carried out by a skilled and authorized staff. The commissioning is easy, but a correct handling and an appropriate maintenance are mandatory to keep the device working perfectly.



## MOUNTING

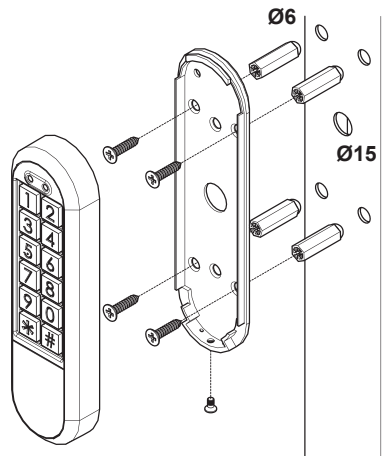
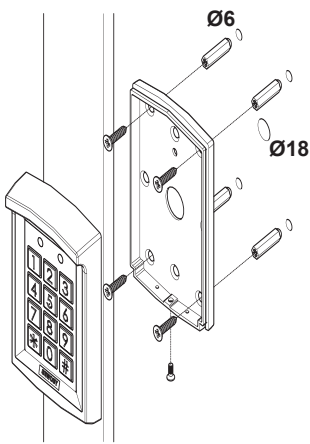

## CONNECTION

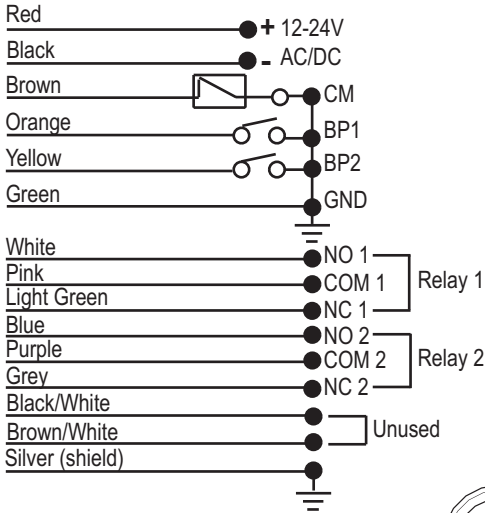
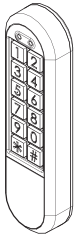
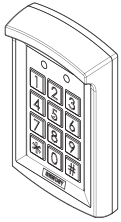

**BP 1**  
= Exit Button Relay 1

**BP 2**  
= Exit Button Relay 2

**CM**  
= Door Magnet\*

  
= Bell\*

\* Please refer to **Bell function** on page 16/24

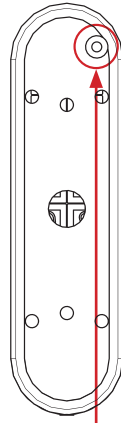
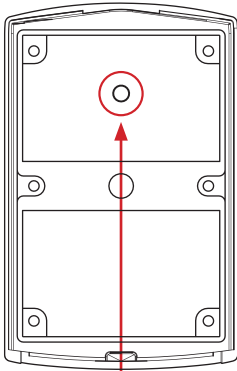

 Anti-tamper photocell. To activate the function, please refer to page 16 «Anti-tamper function»

\***Door magnet** = Detection of door status. When someone opens the door and comes in, the door is closed. The system will automatically detect the door status and lock the door, even though there is still a delay period.

# EXAMPLES FOR TYPICAL WIRING CONFIGURATIONS

## CONNECTION OF AN ELECTRIC STRIKE\* FAIL SECURE LOCKING

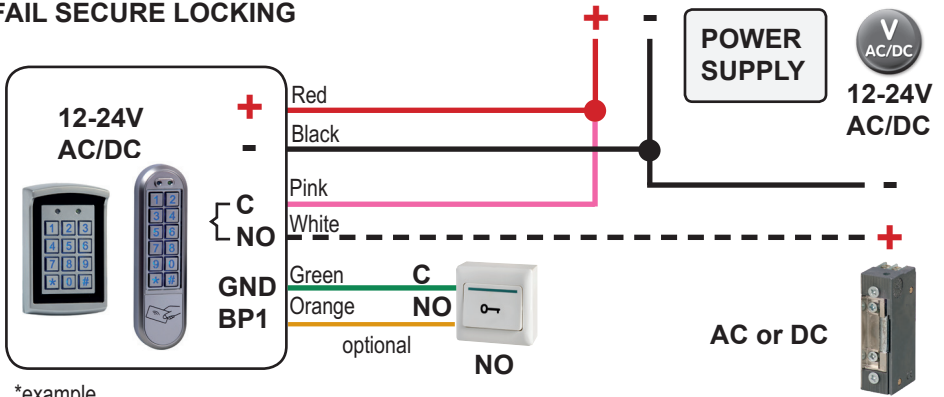

## CONNECTION OF A GATE\* FAIL SECURE LOCKING

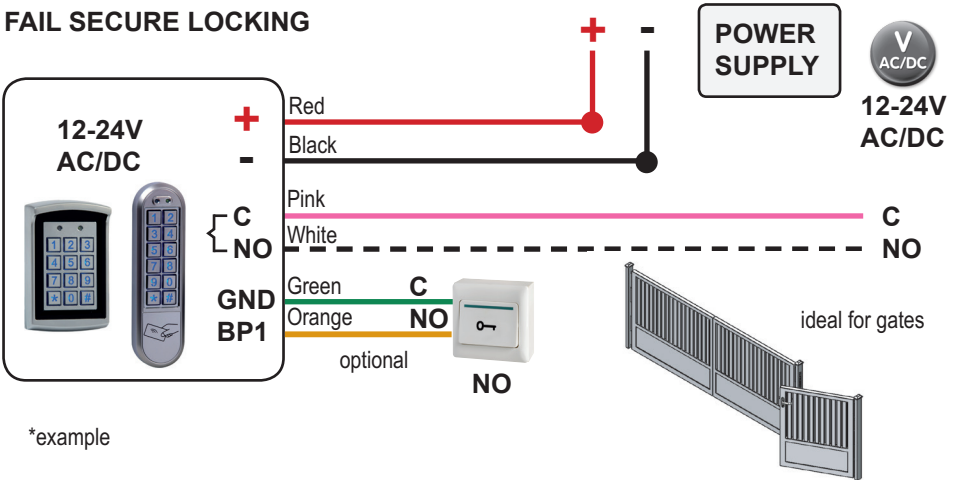

## CONNECTION OF AN EM LOCK\* FAIL SAFE LOCKING

\*example

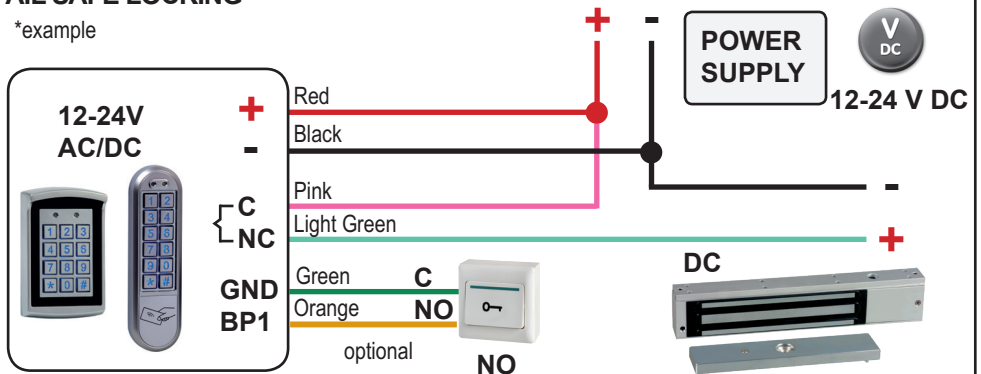

## SETTING MODE

### Changing number of digits (codes)

Attention: this modification must be done before the first programming of a code (factory setting = 4 digits)

|  |   |
|--|---|
| Enter the master code <b>2 X</b> (Default code is 1234)  | long BEEP + right LED will turn yellow  |
| Enter * <b>904</b>   | long BEEP + right LED will flash yellow   |
| Enter the digits ( <b>X</b> is from 2 to 6)<br><b>Changing digit number erases all previous records!</b>   | long BEEP + right LED will turn yellow  |
|  If <b>X</b> = 2 the master code is <b>12</b><br>If <b>X</b> = 3 the master code is <b>123</b><br>If <b>X</b> = 4 the master code is <b>1234</b> | If <b>X</b> = 5 the master code is <b>12345</b><br>If <b>X</b> = 6 the master code is <b>123456</b> |
| Enter <b># #</b>   | right LED will turn green   |

### Create a master card

The master card allows to open the setup session

|   |   |
|---|---|
| Enter the master code <b>2 X</b> (Default code is 1234) | long BEEP + right LED will turn yellow                  |
| Enter * <b>7</b>  | right LED will flash yellow + left LED will flash green |
| Swipe the card <b>1 X</b>                               | long BEEP + right LED will turn yellow                  |
| Enter <b># #</b>  | right LED will turn green                               |

### Changing a master card

|   |  |
|---|--|
| Enter the master code <b>2 X</b> or swipe the master card <b>1 X</b> (Default code is 1234) | long BEEP + right LED will turn yellow                             |
| Enter * <b>7</b>  | right LED will flash yellow + left LED will turn green             |
| Enter <b>**</b>   | long BEEP + right LED will flash yellow + left LED will turn green |
| Swipe the card <b>1 X</b>   | long BEEP + right LED will turn yellow                             |
| Enter <b># #</b>  | right LED will turn green  |

### Changing a master code

It is recommended to modify the master code which allows to open the setup session for security reasons. The user codes must be different from mastercode

|   |  |
|---|--|
| Enter the master code <b>2 X</b> or swipe the master card <b>1 X</b> (Default code is 1234) | long BEEP + right LED will turn yellow |
| Enter * <b>3</b>  | right LED will flash yellow            |
| Enter the new code <b>2 X</b>   | long BEEP + right LED will turn yellow |
| Enter <b># #</b>  | right LED will turn green              |

### How to restore the default master code (1234)

(in case of lost or forgotten master code)

|  |   |
|--|---|
| Switch off the power supply from the keypad<br>Press <b>#</b> key. Keep it pressed for 3 seconds while powering the device again | all LEDs light off<br><br>long BEEP + right LED will turn green |
|--|---|

## Add a user

**ATTENTION: Please note that the master code don't unlock the door!**

### ► RELAY 1 (from 001 to 999 users) ◀

#### CARD OR CODE

|  |   |
|--|---|
| Enter the master code <b>2 X</b> or swipe the master card <b>1 X</b><br>(Default code is 1234) | long BEEP + right LED will turn yellow                    |
| Enter * <b>001</b>   | long BEEP + right LED will turn yellow                    |
| Enter the position from <b>001 to 999</b><br>( <b>3 mandatory digits</b> )                     | left LED will turn green<br>+ right LED will flash yellow |
| <b>if CARD</b> : Swipe the card <b>1 X</b><br><b>if CODE</b> : Enter a code <b>1 X</b>         | long BEEP + right LED will turn yellow                    |
| Enter <b># #</b>   | right LED will turn green                                 |

#### CARD AND CODE

in this case the relay 2 is in idle state (inactive)

|  |   |
|--|---|
| Enter the master code <b>2 X</b> or swipe the master card <b>1 X</b><br>(Default code is 1234) | long BEEP + right LED will turn yellow                    |
| Enter * <b>002</b>   | long BEEP + right LED will turn yellow                    |
| Enter the position from <b>001 to 999</b><br>( <b>3 mandatory digits</b> )                     | left LED will turn green<br>+ right LED will flash yellow |
| Swipe the card <b>1 X</b> and enter a code <b>1 X</b>  | long BEEP + right LED will turn yellow                    |
| Enter <b># #</b>   | right LED will turn green                                 |

### ► RELAY 2 (from 01 to 09 users) ◀

#### CARD OR CODE

|  |   |
|--|---|
| Enter the master code <b>2 X</b> or swipe the master card <b>1 X</b><br>(Default code is 1234) | long BEEP + right LED will turn yellow                    |
| Enter * <b>4</b>   | right LED will flash yellow                               |
| Enter the position from <b>01 to 09</b><br>( <b>2 mandatory digits</b> )                       | left LED will turn green<br>+ right LED will flash yellow |
| <b>if CARD</b> : Swipe the card <b>1 X</b><br><b>if CODE</b> : Enter a code <b>1 X</b>         | long BEEP + right LED will flash yellow                   |
| Enter <b># #</b>   | right LED will turn green                                 |



**The codes or user cards from relay 1 and 2 must be different from each other.**

## Delete one user

### ▶ RELAY 1 (from 001 to 999 users) ◀

|  |   |
|--|---|
| Enter the master code <b>2 X</b> or swipe the master card <b>1 X</b><br>(Default code is 1234) | long BEEP + right LED will turn yellow                                |
| Enter the position (3 mandatory digits)<br>(from 001 to 999)                                   | left LED will turn red<br>+ right LED will flash yellow               |
| Enter **   | long BEEP + left LED will turn green<br>+ right LED will flash yellow |
| Enter # #  | right LED will turn green   |

### ▶ RELAY 2 (from 00 to 09 users) ◀

|  |   |
|--|---|
| Enter the master code <b>2 X</b> or swipe the master card <b>1 X</b><br>(Default code is 1234) | long BEEP + right LED will turn yellow                                |
| Enter * 4  | right LED will flash yellow   |
| Enter the position (2 mandatory digits)<br>(from 00 to 09)                                     | left LED will turn red<br>+ right LED will flash yellow               |
| Enter **   | long BEEP + left LED will turn green<br>+ right LED will flash yellow |
| Enter # #  | right LED will turn green   |

## Delete all users

### All user codes and cards will be removed

|  |  |
|--|--|
| Enter the master code <b>2 X</b> or swipe the master card <b>1 X</b><br>(Default code is 1234) | long BEEP + right LED will turn yellow |
| Enter * 888  | long BEEP + right LED will turn yellow |
| Enter # #  | right LED will turn green              |

## Return to factory settings

### This operation removes all user codes + cards + master card and restores factory settings: default code will be 1234 again

|  |  |
|--|--|
| Enter the master code <b>2 X</b> or swipe the master card <b>1 X</b><br>(Default code is 1234) | long BEEP + right LED will turn yellow |
| Enter * 899  | long BEEP + right LED will turn green  |
| Enter # #  | right LED will turn green              |

## SETTING OF THE UNLOCKING TIME

### ▶ RELAY 1 (from 01 to 99 seconds) ◀

|   |  |
|---|--|
| Enter the master code <b>2 X</b> or swipe the master card <b>1 X</b><br>(Default code is 1234)                | long BEEP + right LED will turn yellow |
| Enter * 1   | right LED will flash yellow            |
| Enter the 2-digits value (mandatory): <b>from 01 to 99 sec.</b><br>or enter <b>00 (for bistable function)</b> | long BEEP + right LED will turn yellow |
| Enter # #   | right LED will turn green              |

### ▶ RELAY 2 (from 01 to 99 seconds) ◀

|   |  |
|---|--|
| Enter the master code <b>2 X</b> or swipe the master card <b>1 X</b><br>(Default code is 1234)                | long BEEP + right LED will turn yellow |
| Enter * 5   | right LED will flash yellow            |
| Enter the 2-digits value (mandatory): <b>from 01 to 99 sec.</b><br>or enter <b>00 (for bistable function)</b> | long BEEP + right LED will turn yellow |
| Enter # #   | right LED will turn green              |

## Buzzer

(If the buzzer is deactivated, the right yellow LED replaces the buzzer's sound)

### ▶ to ENABLE the buzzer ◀

|  |  |
|--|--|
| Enter the master code <b>2 X</b> or swipe the master card <b>1 X</b><br>(Default code is 1234) | long BEEP + right LED will turn yellow |
| Enter * 203  | long BEEP + right LED will turn yellow |
| Enter # #  | right LED will turn green              |

### ▶ to DISABLE the buzzer ◀

|  |  |
|--|--|
| Enter the master code <b>2 X</b> or swipe the master card <b>1 X</b><br>(Default code is 1234) | long BEEP + right LED will turn yellow                     |
| Enter * 204  | left LED will flash yellow<br>+ right LED will turn yellow |
| Enter # #  | left LED will flash yellow<br>+ right LED will turn green  |

## Tamper function

This function activates the buzzer in case of tear-off attempt

### ► to ENABLE the tamper function ◀

|  |  |
|--|--|
| Enter the master code <b>2 X</b> or swipe the master card <b>1 X</b><br>(Default code is 1234) | long BEEP + right LED will turn yellow |
|--|--|

|           |                             |
|-----------|-----------------------------|
| Enter * 6 | right LED will flash yellow |
|-----------|-----------------------------|

|          |  |
|----------|--|
| Enter 02 | long BEEP + right LED will turn yellow |
|----------|--|

|           |                           |
|-----------|---------------------------|
| Enter # # | right LED will turn green |
|-----------|---------------------------|

### ► to DISABLE the tamper function ◀

|  |  |
|--|--|
| Enter the master code <b>2 X</b> or swipe the master card <b>1 X</b><br>(Default code is 1234) | long BEEP + right LED will turn yellow |
|--|--|

|           |                             |
|-----------|-----------------------------|
| Enter * 6 | right LED will flash yellow |
|-----------|-----------------------------|

|          |  |
|----------|--|
| Enter 01 | long BEEP + right LED will turn yellow |
|----------|--|

|           |                           |
|-----------|---------------------------|
| Enter # # | right LED will turn green |
|-----------|---------------------------|



## Bell function

If the bell function is activated,  
the programmed cards and codes will no longer be functional on relay 2.  
This function could be used as a bell.  
Press on \* key to ring the bell.

### ► to ENABLE the bell function ◀

|  |  |
|--|--|
| Enter the master code <b>2 X</b> or swipe the master card <b>1 X</b><br>(Default code is 1234) | long BEEP + right LED will turn yellow |
|--|--|

|           |                             |
|-----------|-----------------------------|
| Enter * 2 | right LED will flash yellow |
|-----------|-----------------------------|

|          |                                   |
|----------|-----------------------------------|
| Enter 02 | BIP long + LED droite orange fixe |
|----------|-----------------------------------|

|           |                           |
|-----------|---------------------------|
| Enter # # | right LED will turn green |
|-----------|---------------------------|

### ► to DISABLE the bell function ◀

|  |  |
|--|--|
| Enter the master code <b>2 X</b> or swipe the master card <b>1 X</b><br>(Default code is 1234) | long BEEP + right LED will turn yellow |
|--|--|

|           |                             |
|-----------|-----------------------------|
| Enter * 2 | right LED will flash yellow |
|-----------|-----------------------------|

|          |  |
|----------|--|
| Enter 01 | long BEEP + right LED will turn yellow |
|----------|--|

|           |                           |
|-----------|---------------------------|
| Enter # # | right LED will turn green |
|-----------|---------------------------|

**Remark:** If three consecutive keyboard input errors occurred, the keyboard will be locked for 60 seconds. Any keyboard operation is invalid within 60 seconds.





### TECHNISCHE DATEN

|                                      |                        |  |                 |        |                          |                               |                              |  |     |
|--------------------------------------|------------------------|--|-----------------|--------|--------------------------|-------------------------------|------------------------------|--|-----|
| H x B x T                            |                        |  |                 |        |                          |                               |                              |  |     |
| 120 x 76 x 28 mm<br>165 x 45 x 22 mm |                        | 0,7 kg<br>0,6 kg   | 12/24V<br>AC/DC | 110 mA | Relais<br>Ausgang<br>= 2 | 30V DC - 2 A<br>125VAC - 0,5A | Druckknopf<br>Eingang<br>= 2 | 1010<br>Relais 1 = 1000<br>Relais 2 = 10 | 65* |
| <b>K1000</b>                         |                        | <b>1 Betriebsmodus:</b><br>• TÜRCODESYSTEM (TASTATUR)<br>➔ <b>ACHTUNG:</b><br><i>jeder Code ist ein Unikat</i>   |                 |        |                          |                               |                              | 0 - 99 s                                 |     |
| <b>KR1000<br/>KRN1000</b>            | <br>125 KHz<br>(MARIN) | <b>3 Betriebsmodus:</b><br>• BERÜHRUNGSLOSER KARTENLESER<br>• KARTENLESER oder TÜRCODESYSTEM<br>• BERÜHRUNGSLOSER KARTENLESER + CODE<br>➔ <b>ACHTUNG:</b><br><i>in diesem Fall müssen alle Benutzer 1 CODE und 1 BERÜHRUNGSLOSE KARTE besitzen</i> |                 |        |                          |                               |                              | -10+60°C                                 |     |

\*IP 65 : staubdicht. Schutz gegen Strahlwasser.

### ABMESSUNGEN

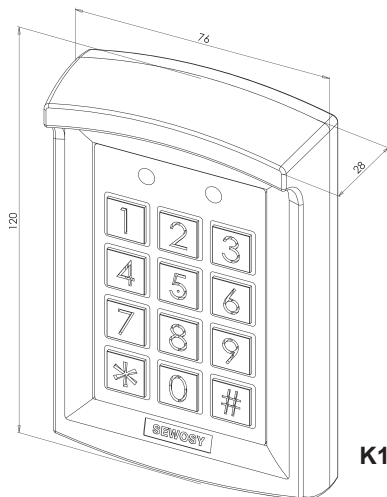

**K1000 - KR1000**

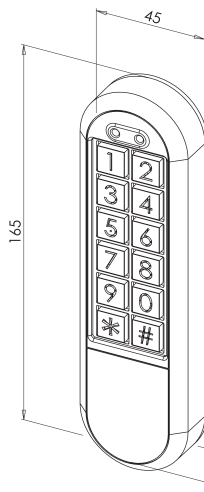

**KRN1000**

### **ACHTUNG: Anschlußpolarität und Höhe der Betriebsspannung beachten (12/24V AC/DC)!**

Vor der Inbetriebnahme, bitte diese Anleitung sorgfältig lesen. Dieses Material nur für vorgesehene Anwendungen einsetzen. Der Hersteller leistet keine Gewähr für Schäden die durch fehlerhafte Montage oder nicht einhalten von Sicherheitsvorschriften entstehen.

Die Montage, die Wartung und Reparaturen dürfen nur durch sachkundiges Personal durchgeführt werden.

Die Montage ist sehr einfach, aber eine korrekte Verarbeitung und ein entsprechender Unterhalt sind grundsätzliche Bedingungen für eine einwandfreie Funktion.

# MONTAGE

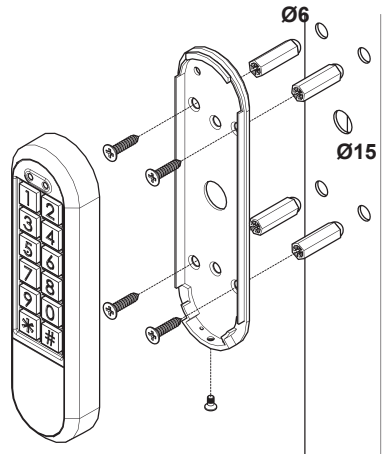
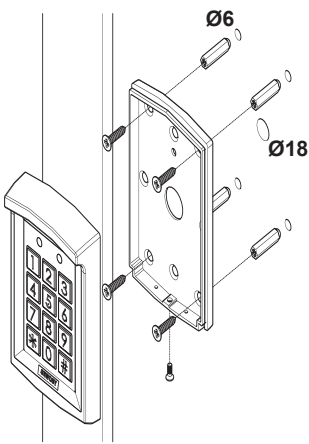

# ANSCHLUß

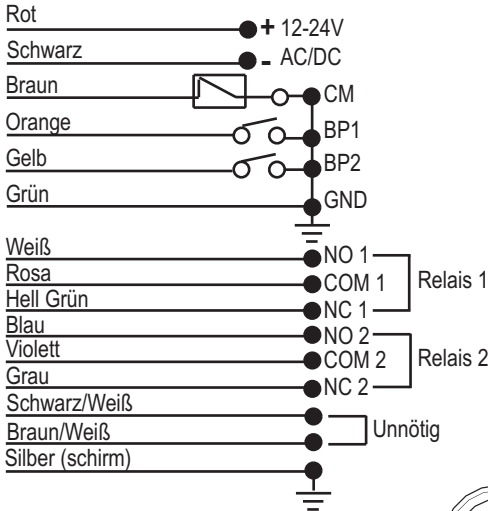
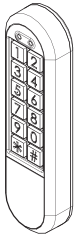
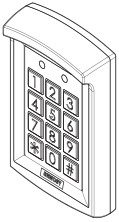

**BP 1**  
= Druckknopf Relais 1

**BP 2**  
= Druckknopf Relais 2

**CM**  
= Magnetkontakt\*

  
= Klingel\*

\* Siehe **Klingeltaster Funktion** Seite 24/24

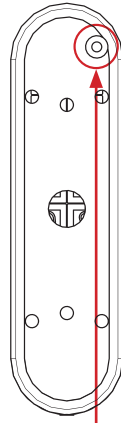
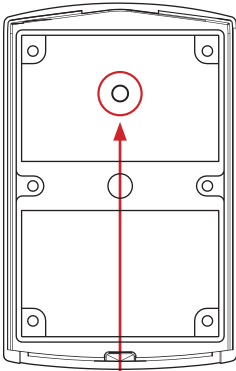

 Fotozelle für Sabotagealarm. Um diese Funktion zu aktivieren, Siehe Seite 24/24 «Sabotagealarm»

\***Magnetkontakt** = Türzustandsanzeige. Falls jemand die Tür geöffnet hat und eingetreten ist, und diese danach wieder geschlossen ist, detektiert das Gerät automatisch die Türposition und verriegelt die Tür. Dies erfolgt obgleich eine Entriegelungszeit eingestellt wurde.

**ARBEITSSTROM VERRIEGELUNG  
MIT TÜRÖFFNER ANSCHLUß\***

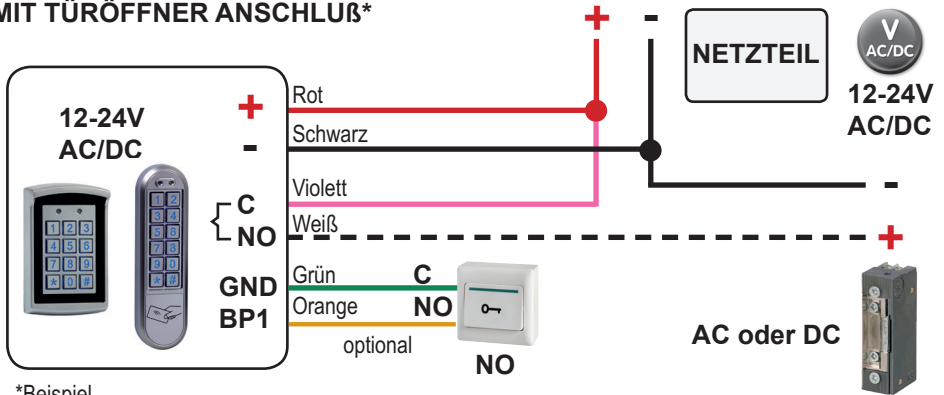

\*Beispiel

**ARBEITSSTROM VERRIEGELUNG  
MIT AUSSENTOR ANSCHLUß\***

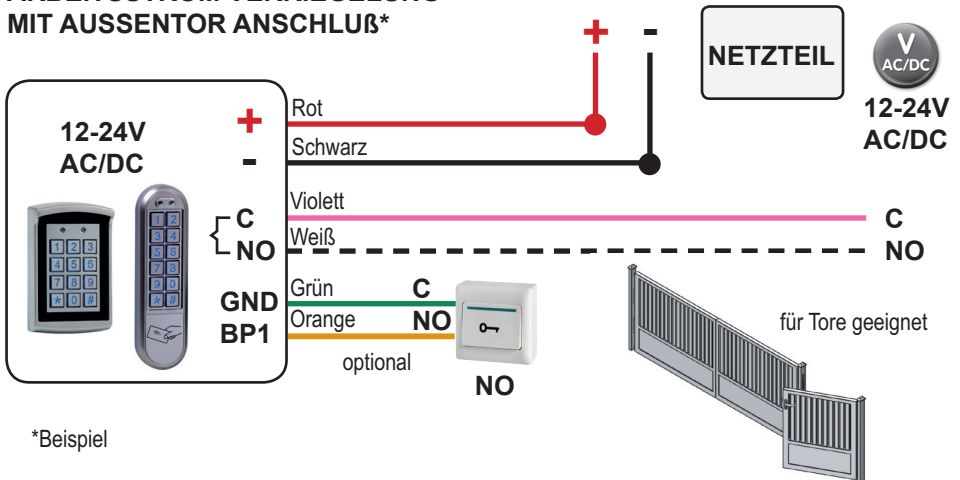

\*Beispiel

**RUHESTROM VERRIEGELUNG  
MIT HAFTMAGNET ANSCHLUß\***

\*Beispiel

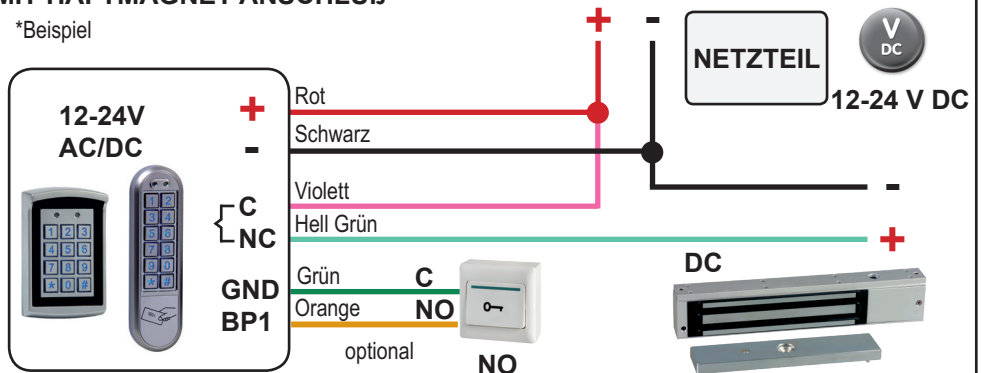

## PROGRAMMIERUNG

### Änderung der Zifferanzahl (Codes)

Achtung: diese Änderung muss vor der ersten Codeprogrammierung erfolgen (Werkeinstellung = 4 Ziffern)

|  |   |
|--|---|
| 2 X Mastercode eingeben (Ursprungsmastercode: 1234)                              | langer PIEP Ton + rechte gelbe LED leuchtet |
| * 904 eingeben   | langer PIEP Ton + rechte gelbe LED blinkt   |
| Neuer Wert eingeben (X zwischen 2 und 6 begriffen)                               | langer PIEP Ton + rechte gelbe LED leuchtet |
| <b>Eine Änderung der Zifferanzahl löscht alle vorrige Speicherungen!</b>         |   |
|  | Falls X = 2, ist der Mastercode 12          |
|  | Falls X = 3, ist der Mastercode 123         |
|  | Falls X = 4, ist der Mastercode 1234        |
|  | Falls X = 5, ist der Mastercode 12345       |
|  | Falls X = 6, ist der Mastercode 123456      |
| # # eingeben   | rechte grüne LED leuchtet                   |

### Masterkarte kreieren

Die Masterkarte ermöglicht in den Programmiermodus zu gelangen

|   |   |
|---|---|
| 2 X Mastercode eingeben (Ursprungsmastercode: 1234) | langer PIEP Ton + rechte gelbe LED leuchtet       |
| * 7 eingeben  | rechte gelbe LED blinkt + linkse grüne LED blinkt |
| 1 X Karte an den Leser halten                       | langer PIEP Ton + rechte gelbe LED leuchtet       |
| # # eingeben  | rechte grüne LED leuchtet                         |

### Masterkarte ändern

|  |   |
|--|---|
| 2 X Mastercode eingeben oder 1 X Masterkarte an den Leser halten (Ursprungsmastercode: 1234) | langer PIEP Ton + rechte gelbe LED leuchtet                           |
| * 7 eingeben   | rechte gelbe LED blinkt + linkse grüne LED leuchtet                   |
| ** eingeben  | langer PIEP Ton + rechte gelbe LED blinkt + linkse grüne LED leuchtet |
| 1 X Karte an den Leser halten  | langer PIEP Ton + rechte gelbe LED leuchtet                           |
| # # eingeben   | rechte grüne LED leuchtet   |

### Mastercode ändern

Der Mastercode ermöglicht in den Programmiermodus zu gelangen. Sicherheitshalber wird empfohlen ihn zu ändern. Es darf kein Benutzercode identisch sein.

|  |   |
|--|---|
| 2 X Mastercode eingeben oder 1 X Masterkarte an den Leser halten (Ursprungsmastercode: 1234) | langer PIEP Ton + rechte gelbe LED leuchtet |
| * 3 eingeben   | rechte gelbe LED blinkt                     |
| Neuer Code 2 X eingeben  | langer PIEP Ton + rechte gelbe LED leuchtet |
| # # eingeben   | rechte grüne LED leuchtet                   |

### Wiederherstellung des Ursprungsmastercodes (1234)

(Falls der Mastercode vergessen oder verloren ging)

|  |  |
|--|--|
| Stromzufuhr des Gerätes abschalten<br>Auf die Taste # 3 Sek. anhaltend drücken, während die Stromzufuhr wiederhergestellt wird | Alle LEDs löschen<br><br>langer PIEP Ton + rechte grüne LED leuchtet |
|--|--|

## Benutzer Speicherung

**ACHTUNG: Der Mastercode entriegelt die Tür nicht!**

► **RELAIS 1 (von 001 bis 999 Benutzer)** ◀

### KARTE ODER CODE

|   |  |
|---|--|
| <b>2 X</b> Mastercode eingeben oder <b>1 X</b> Masterkarte an den Leser halten ( <b>Ursprungsmastercode: 1234</b> ) | langer PIEP Ton + rechte gelbe LED leuchtet                              |
| * <b>001</b> eingeben   | langer PIEP Ton + rechte gelbe LED leuchtet                              |
| Position eingeben: von <b>001 bis 999</b><br>( <b>dreistellige Ziffernanzahl obligatorisch</b> )                    | linkse grüne LED leuchtet<br>+ rechte gelbe LED blinkt                   |
| <b>Falls KARTE:</b> <b>1 X</b> Karte an den Leser halten<br><b>Falls CODE:</b> <b>1 X</b> Code eingeben             | langer PIEP Ton + linkse grüne LED leuchtet<br>+ rechte gelbe LED blinkt |
| <b># #</b> eingeben   | rechte grüne LED leuchtet  |

### KARTE UND CODE

In diesem Fall ist Relais 2 im Ruhezustand (inaktiv)

|   |  |
|---|--|
| <b>2 X</b> Mastercode eingeben oder <b>1 X</b> Masterkarte an den Leser halten ( <b>Ursprungsmastercode: 1234</b> ) | langer PIEP Ton + rechte gelbe LED leuchtet            |
| * <b>002</b> eingeben   | langer PIEP Ton + rechte gelbe LED leuchtet            |
| Position eingeben: von <b>001 bis 999</b><br>( <b>dreistellige Ziffernanzahl obligatorisch</b> )                    | linkse grüne LED leuchtet<br>+ rechte gelbe LED blinkt |
| <b>1 X</b> Karte an den Leser halten und <b>1 X</b> Code eingeben   | langer PIEP Ton + rechte gelbe LED leuchtet            |
| <b># #</b> eingeben   | rechte grüne LED leuchtet                              |

► **RELAIS 2 (von 00 bis 09 Benutzer)** ◀

### KARTE ODER CODE

|   |  |
|---|--|
| <b>2 X</b> Mastercode eingeben oder <b>1 X</b> Masterkarte an den Leser halten ( <b>Ursprungsmastercode: 1234</b> ) | langer PIEP Ton + rechte gelbe LED leuchtet            |
| * <b>4</b> eingeben   | rechte gelbe LED blinkt                                |
| Position eingeben: von <b>01 bis 09</b><br>( <b>zweistellige Ziffernanzahl obligatorisch</b> )                      | linkse grüne LED leuchtet<br>+ rechte gelbe LED blinkt |
| <b>Falls KARTE:</b> <b>1 X</b> Karte an den Leser halten<br><b>Falls CODE:</b> <b>1 X</b> Code eingeben             | langer PIEP Ton + rechte gelbe LED blinkt              |
| <b># #</b> eingeben   | rechte grüne LED leuchtet                              |



**Die Benutzer- Karten oder Codes von den Relais 1 und 2 müssen unterschiedlich sein.**

## Ein Benutzer löschen

### ► RELAIS 1 (von 001 bis 999 Benutzer) ◀

|  |   |
|--|---|
| 2 X Mastercode eingeben oder 1 X Masterkarte an den Leser halten (Ursprungsmastercode: 1234) | langer PIEP Ton + rechte gelbe LED leuchtet                             |
| Position eingeben: von 001 bis 999 (dreistellige Ziffernanzahl obligatorisch)                | linke rote LED leuchtet<br>+ rechte gelbe LED blinkt                    |
| ** eingeben  | langer PIEP Ton + linke grüne LED leuchtet<br>+ rechte gelbe LED blinkt |
| # # eingeben   | rechte grüne LED leuchtet   |

### ► RELAIS 2 (von 00 bis 09 Benutzer) ◀

|  |   |
|--|---|
| 2 X Mastercode eingeben oder 1 X Masterkarte an den Leser halten (Ursprungsmastercode: 1234) | langer PIEP Ton + rechte gelbe LED leuchtet                             |
| * 4 eingeben   | rechte gelbe LED blinkt   |
| Position eingeben: von 00 bis 09 (zweistellige Ziffernanzahl obligatorisch)                  | linke rote LED leuchtet<br>+ rechte gelbe LED blinkt                    |
| ** eingeben  | langer PIEP Ton + linke grüne LED leuchtet<br>+ rechte gelbe LED blinkt |
| # # eingeben   | rechte grüne LED leuchtet   |

## Alle Benutzer löschen

### Alle Codes und Benutzerkarten werden gelöscht

|  |   |
|--|---|
| 2 X Mastercode eingeben oder 1 X Masterkarte an den Leser halten (Ursprungsmastercode: 1234) | langer PIEP Ton + rechte gelbe LED leuchtet |
| * 888 eingeben   | langer PIEP Ton + rechte gelbe LED leuchtet |
| # # eingeben   | rechte grüne LED leuchtet                   |

## Rückkehr zur Ursprungeinstellung

Das Zurücksetzen in den Installationsmodus löscht alle Codes und Benutzerkarten sowie der eingegebene Mastercode und hat die Wiederherstellung des Ursprungsmastercode zufolge (1234)

|  |   |
|--|---|
| 2 X Mastercode eingeben oder 1 X Masterkarte an den Leser halten (Ursprungsmastercode: 1234) | langer PIEP Ton + rechte gelbe LED leuchtet |
| * 899 eingeben   | langer PIEP Ton + rechte grüne LED blinkt   |
| # # eingeben   | rechte grüne LED leuchtet                   |

## Entriegelungszeit: Einstellung der Relais

### ▶ RELAIS 1 (von 01 bis 99 Sekunden) ◀

|   |   |
|---|---|
| 2 X Mastercode eingeben oder 1 X Masterkarte an den Leser halten (Ursprungsmastercode: 1234)                              | langer PIEP Ton + rechte gelbe LED leuchtet |
| * 1 eingeben  | rechte gelbe LED blinkt                     |
| Zeit Wert eingeben: von 01 bis 99 Sek.<br>(zweistellige Ziffernanzahl obligatorisch)<br>oder 00 eingeben (bistabil Modus) | langer PIEP Ton + rechte gelbe LED leuchtet |
| # # eingeben  | rechte grüne LED leuchtet                   |

### ▶ RELAIS 2 (von 01 bis 99 Sekunden) ◀

|   |   |
|---|---|
| 2 X Mastercode eingeben oder 1 X Masterkarte an den Leser halten (Ursprungsmastercode: 1234)                              | langer PIEP Ton + rechte gelbe LED leuchtet |
| * 5 eingeben  | rechte gelbe LED blinkt                     |
| Zeit Wert eingeben: von 01 bis 99 Sek.<br>(zweistellige Ziffernanzahl obligatorisch)<br>oder 00 eingeben (bistabil Modus) | langer PIEP Ton + rechte gelbe LED leuchtet |
| # # eingeben  | rechte grüne LED leuchtet                   |

## Summer

(Ist der Summer deaktiviert, ersetzt die linke orange LED den Summertone)

### ▶ AKTIVIEREN ◀

|  |   |
|--|---|
| 2 X Mastercode eingeben oder 1 X Masterkarte an den Leser halten (Ursprungsmastercode: 1234) | langer PIEP Ton + rechte gelbe LED leuchtet |
| * 203 eingeben   | langer PIEP Ton + rechte gelbe LED leuchtet |
| # # eingeben   | rechte grüne LED leuchtet                   |

### ▶ DEAKTIVIEREN ◀

|  |   |
|--|---|
| 2 X Mastercode eingeben oder 1 X Masterkarte an den Leser halten (Ursprungsmastercode: 1234) | langer PIEP Ton + rechte gelbe LED leuchtet           |
| * 204 eingeben   | linke rote LED blinkt<br>+ rechte gelbe LED leuchtet  |
| # # eingeben   | linke gelbe LED blinkt<br>+ rechte grüne LED leuchtet |

## Sabotagealarm

Diese Funktion aktiviert den Summer im Falle eines Vandalismusversuchs (Abreißen des Geräts)

### ▶ AKTIVIEREN ◀

|   |   |
|---|---|
| 2 X Mastercode eingeben oder 1 X Masterkarte an den Leser halten ( <b>Ursprungsmastercode: 1234</b> ) | langer PIEP Ton + rechte gelbe LED leuchtet |
| * 6 eingeben  | rechte gelbe LED blinkt                     |
| 02 eingeben   | langer PIEP Ton + rechte gelbe LED leuchtet |
| # # eingeben  | rechte grüne LED leuchtet                   |

### ▶ DEAKTIVIEREN ◀

|   |   |
|---|---|
| 2 X Mastercode eingeben oder 1 X Masterkarte an den Leser halten ( <b>Ursprungsmastercode: 1234</b> ) | langer PIEP Ton + rechte gelbe LED leuchtet |
| * 6 eingeben  | rechte gelbe LED blinkt                     |
| 01 eingeben   | langer PIEP Ton + rechte gelbe LED leuchtet |
| # # eingeben  | rechte grüne LED leuchtet                   |



## Klingeltaster Funktion

Ist die Klingeltaster Funktion aktiviert, so sind die programmierten Karten und Codes auf dem Relais 2 nicht mehr funktionsfähig.

Diese Funktion kann die Türklingel ersetzen.

Betätigen des Klingeltasters ⇨ auf Taste \* drücken.

### ▶ AKTIVIEREN ◀

|   |   |
|---|---|
| 2 X Mastercode eingeben oder 1 X Masterkarte an den Leser halten ( <b>Ursprungsmastercode: 1234</b> ) | langer PIEP Ton + rechte gelbe LED leuchtet |
| * 2 eingeben  | rechte gelbe LED blinkt                     |
| 02 eingeben   | langer PIEP Ton + rechte gelbe LED leuchtet |
| # # eingeben  | rechte grüne LED leuchtet                   |

### ▶ DEAKTIVIEREN ◀

|   |   |
|---|---|
| 2 X Mastercode eingeben oder 1 X Masterkarte an den Leser halten ( <b>Ursprungsmastercode: 1234</b> ) | langer PIEP Ton + rechte gelbe LED leuchtet |
| * 2 eingeben  | rechte gelbe LED blinkt                     |
| 01 eingeben   | langer PIEP Ton + rechte gelbe LED leuchtet |
| # # eingeben  | rechte grüne LED leuchtet                   |

**Beachten Sie:** Nach fünf unberechtigten Betätigungen (Codes), befindet sich die Tastatur während 60 Sek. im gesperrten Zustand. Während dieser Zeit können keine Manipulationen durchgeführt werden!